

版次	修改内容	日期

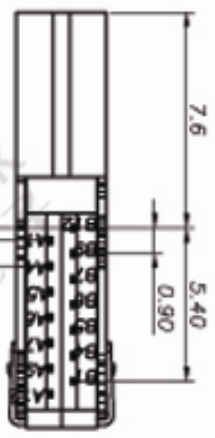

- NOTE:
- 1.MATERIAL SPECIFICATION:
  - 1.HOUSING: LCP, UL94 V-0.
  - 2.CONTACTS: COPPER ALLOY(C18184)
  - 3.MID PLATE: STAINLESS STEEL(SUS301)
  - 4.FRONT SHELL: STAINLESS STEEL(SUS304)
  - 5.EMI PLATE: STAINLESS STEEL(SUS304)
- 2.PLATING SPECIFICATION:
- 2-1.CONTACTS:  
Ni 50μ" MIN. UNDER PLATED OVER ALL.  
Au PLATED ON THE FUNCTIONAL AREA OF CONTACT.  
(GOLD PLATING THICKNESS FOLLOW THE P/N)
  - 2-2.FRONT SHELL:  
Ni 30μ" MIN. UNDER PLATED OVER ALL.
  - 2-3.MID PLATE&EMI PLATE:  
CLEAR ONLY
- 3.MECHANICAL PERFORMANCE:
- 3-1.INSERTION FORCE: 0.5~2.0kgf.
  - 3-2.REMOVAL FORCE: 0.8kgf~2.0kgf.
  - 3-3.DURABILITY: 10000 CYCLES.
- 4.ELECTRICAL PERFORMANCE:
- 4-1. CURRENT RATING:5.0A  
VOLTAGE RATING:5.0V
  - 4-2. ILCR:  
VBUS & GND PINS AND OTHER PINS: 40mΩ/PIN MAX.  
SHIELD: 50mΩ/MAX.  
ILCR MAX. CHANGE OF ALL PINS: 10mΩ.
  - 4-3.INSULATION RESISTANCE: 100MΩ MIN
  - 4-4.DIELECTRIC WITHSTAND VOLTAGE:AC 100V FOR 1 MINUTE.
5. ENVIRONMENTAL PERFORMANCE:
- OPERATING TEMPERATURE: -25~+85℃.
- 6.R REFLOW:  
THE PEAK TEMPERATURE ON THE BOARD SHALL BE MAINTAINED FOR 10 SECONDS AT 260°C.

核准		未注公差	X.X ±0.20	ACH 雅創電子有限公司 ACH ELECTRONICS CO., LTD TEL: 0755-88219101/FAX: 0755-88219123
审核		X.XX ±0.15		
设计	lcy	2017-08-31	X.XXX ±0.05	品名 USB CF 14PIN FLAG TYPE
单位	mm	版次	A/0	圖號
				客戶料號

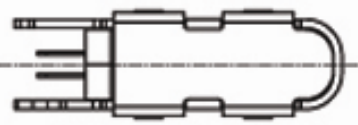
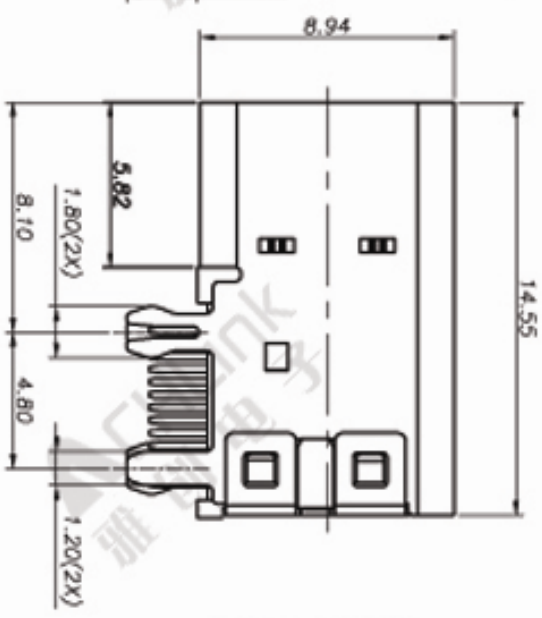
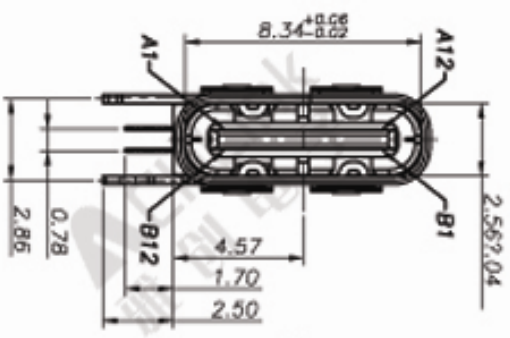

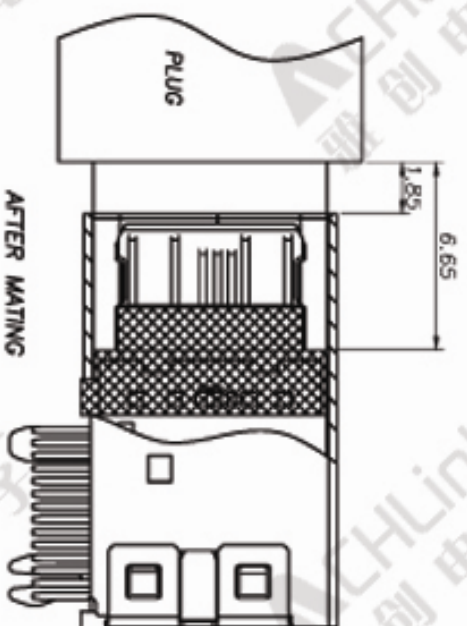

USB TYPE-C PIN ASSIGNMENTS

PIN NUMBER	SIGNAL NAME	PIN NUMBER	SIGNAL NAME
A1	GND	B12	GND
A4	VBUS	B9	VBUS
A5	CC1	B7	Dn2
A6	Dp1	B6	Dp2
A7	Dn1	B5	CC2
A9	VBUS	B4	VBUS
A12	GND	B1	GND

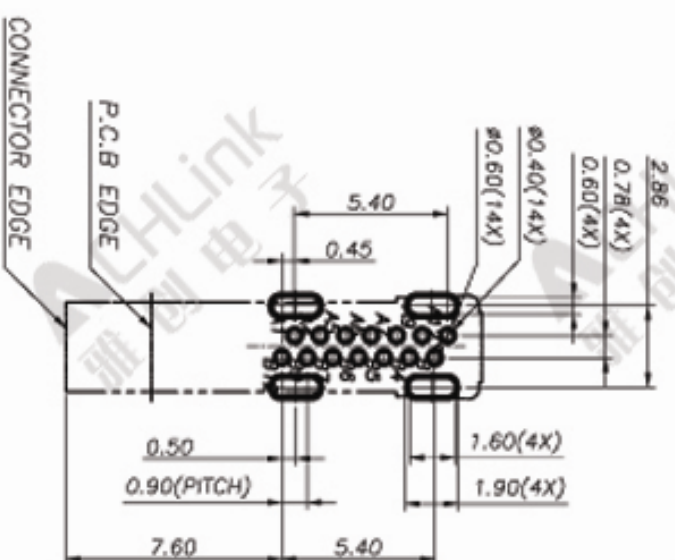

RECOMMENDED PCB LAYOUT(TOP VIEW)  
THICKNESS: 1.62, 1.0MM; DEFAULT TOLERANCE: 2.05

版次	修改内容	日期

核准		未注公差	X, X ±0.20	ACH 雅创电子有限公司 ACH ELECTRONICS CO., LTD TEL: 0754-6821910/FAX: 0753-68219123
审核		X, XX ±0.15		
设计	LCY	2017-08-31	X, XXX ±0.05	品名 USB CF 14PIN FLAG TYPE
单位	mm	版次	A/0	图号
				客户料号

版次	修改内容	日期

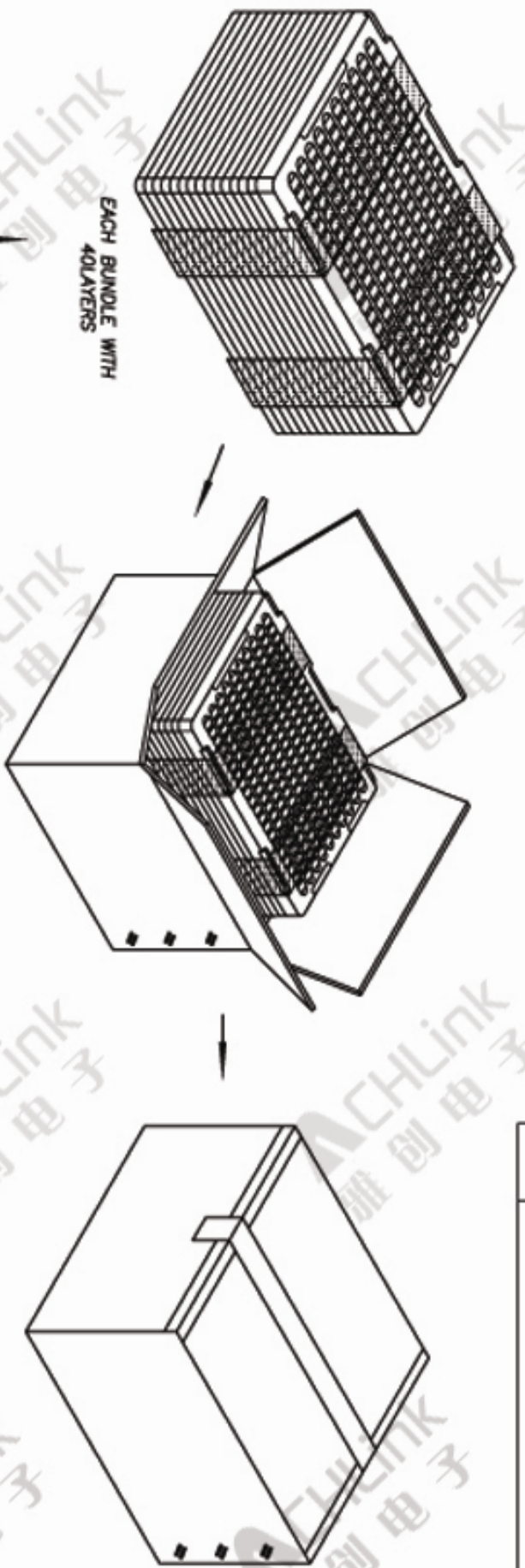

EACH BUNDLE WITH  
40LAYERS

EACH CARTON WITH  
6800 PCS PRODUCTS

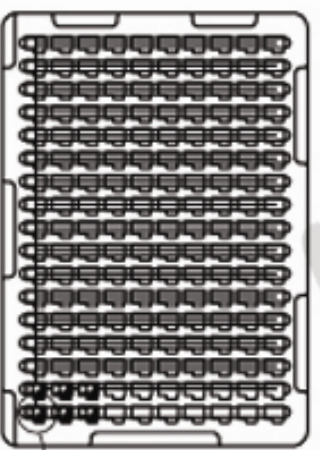

170PCS/TRAY

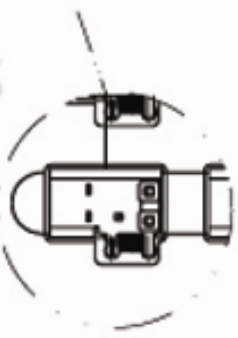

核准		未注公差	X. X ±0.20	ACH 雅創電子有限公司 ACH ELECTRONICS CO., LTD TEL: 0754-88219101/FAX: 0750-88219123	
审核		X. XX ±0.15			
设计	1cy	2017-08-31	X. XXX ±0.05	品名	USB CF 14PIN FLAG TYPE
	单位	版次	客户編號	圖號	
	mm	A/0	客户料號		

