

REV	DESCRIPTION	DATE

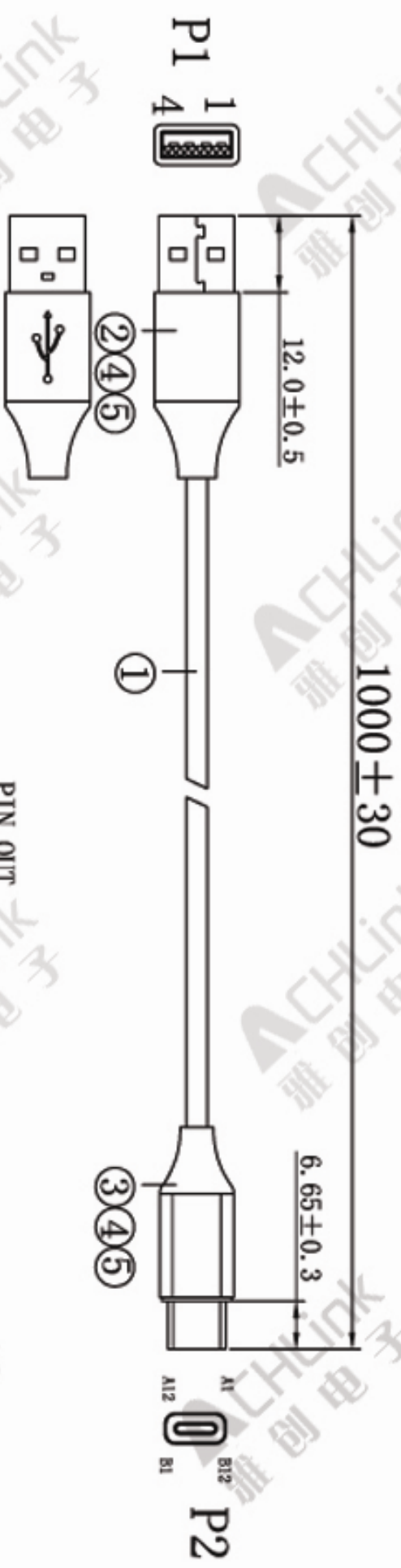

1. TESTING CONDITIONS:
 A. 100% QC OPEN SHORT & MISS WIRING TEST
 B. INSULATION RESISTANCE: DC300V 5Mohm MIN
 C. CONDUCTOR RESISTANCE 3ohm Max

Would No. : P1: B266/B223 P2: B267

P1	1	Red	P2	A4, B4, A9, B9
	2	White		A7
	3	Green		A6
	4	Black		A1, B1, A12, B12



⑧	IPC	Carton 460*300*250mm	F06-403025-001
⑦	IPC	PE Transparent Heat Sealing Plastic Bags : 270*350*0.05mm	F05-273505-002
⑥	IPC	Ordinary band white	F01-080000-004
⑤	A/R	Aluminium alloy shell	P2-1500-001
④	A/R	PVC 45P-R0 White	P1-0445-001
③	IPC	USB Type-C with PCB Board 2.0 Stretching	C211-0204-010
②	IPC	USB 2.0 AM Short body white rubber core	C241-0405-001
①	IPC	NO-012725*30*2C (7/0.10BC) +28*2C(17/0.10BC) L=1000mm	X275-041238-641
NO	Design	Description	Part No

APPROVED:	UNLESS OTHERWISE SPECIFIED TOLERANCE	ACH VACUUM TECHNOLOGY HOLDINGS LIMITED TEL.: 0755-88210101/FAX: 0755-88210123
CHECKED:	X.X ± 0.20	
DRAWN:	1cy	DRAWN NAME: USB2.0 AM TO Type-C M L-1000mm PRODUCT NO: CUSTOMER P/N:
UNIT	mm	
REV	A/0	
CUSTOMER NO:		